



Reliable  
Refrigeration  
Solutions



# Doughnut Fryer System

## MEFD

Proofer and fryer in one!  
Ideal for popular menu items such as  
doughnuts and curry bread.





**MEFD-18GL MEFD-18RCL MEFD-23GL MEFD-23RCL**

Oil amount  
18ℓ



Oil amount  
23ℓ



Model	Description
MEFD-18GL	Size: 480(W) x 600(D) x 850(H) Capacity: 18L
MEFD-23GL	Size: 600(W) x 600(D) x 850(H) Capacity: 23L
MEFD-18RCL	Size: 450(W) x 600(D) x 895(H)
MEFD-23RCL	Size: 570(W) x 600(D) x 895(H)





**MEFD-18GL MEFD-18RCL**

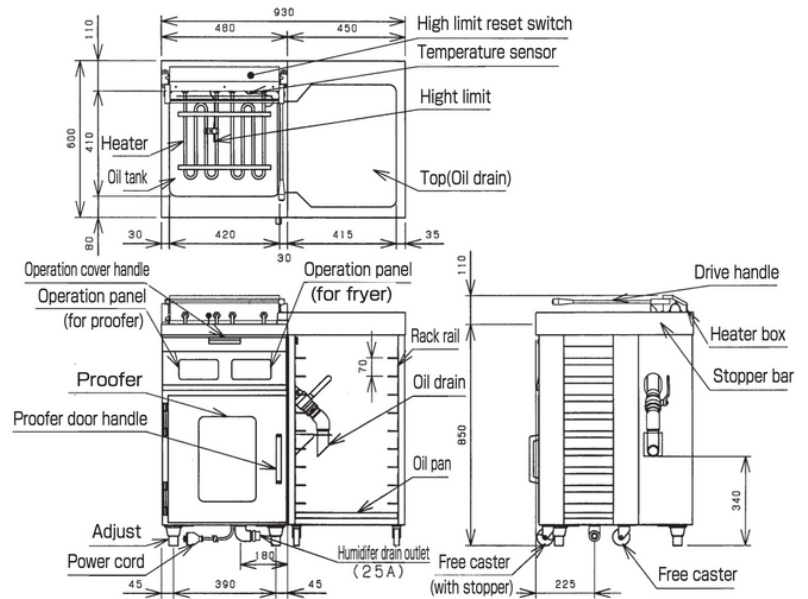

\*Comes with Cover, Oil tank (large), Oil filtering net, Flat net×5, Flat net receiver

**SPECIFICATIONS**

Model	Dimensions (mm)	Weight	Capacity	Power
MEFD-18GL	480(W) x 600(D) x 850(H)	53.5KG	18L	3 Phase / 220V 3.95Kw
MEFD-18RCL	450(W) x 600(D) x 895(H)	20.5KG	NIL	NIL





**MEFD-23GL MEFD-23RCL**

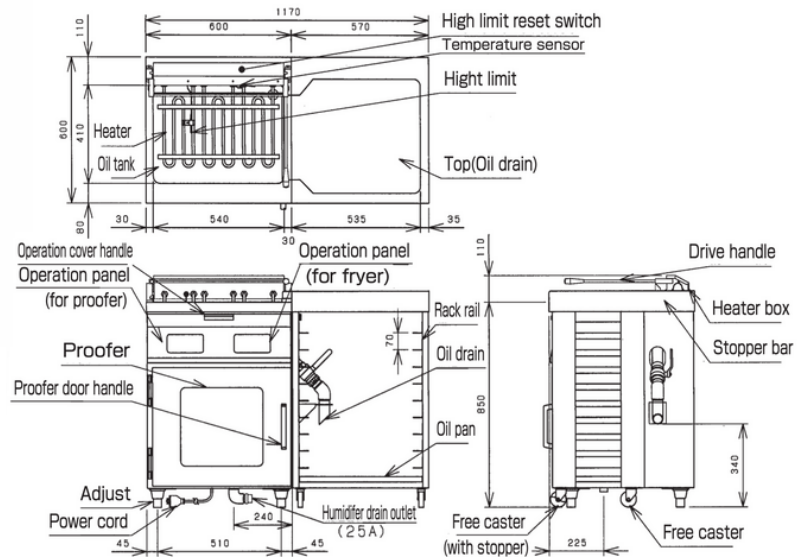

\*Comes with Cover, Oil tank (large), Oil filtering net, Flat net×5, Flat net receiver

**SPECIFICATIONS**

Model	Dimension	Weight	Capacity	Power
MEFD-23GL	600(W) x 600(D) x 850(H)	59.5KG	23L	3 Phase / 220V 5.75Kw
MEFD-23RCL	570(W) x 600(D) x 895(H)	22KG	NIL	NIL

